

Also available from SECO-LARM:

E-960-D290Q



Twin Photobeam Detectors

- Range: up to 290' outdoors.
- Lensed optics reinforce beam strength and provide excellent immunity to false alarms due to rain, snow, mist, etc.
- Weatherproof, sunlight filtering case for indoor and outdoor conditions.
- Quick easy installation with built-in laser-beam alignment system.

E-932-D33TBQ



Flush-Mount Photobeam Sensors

- E-932-D33TBQ – Photoelectric Through-Beam Sensor.
- E-932-S16RRQ – Photoelectric Reflective-Beam Sensor.
- Suitable for entrances, hallways, room in office or home.
- Fits single-gang box.
- Adjustable alignment angle from +/-15° horizontally / vertically.

E-932-S16RRQ



E-9622-4B25



Curtain / Barrier Sensors

- Available in 4, 6, 8 or 10 beams.
- Range: 25 ft. outdoor, 50 ft. indoor.
- Slim-line design 7/8" x 1 5/16".
- Weatherproof IP65 construction.
- Triggers on breaking of any single or 2 adjacent beams (programmable).

ENFORCER[®] SENSOR

MANUAL

Multi-Frequency

Quad Photobeam Detectors

- E-964-Q660Q – 660 ft. (200m) outdoors, 1320 ft. (400m) indoors
- E-964-Q495Q – 495 ft. (150m) outdoors, 990 ft. (300m) indoors
- E-964-Q330Q – 330 ft. (100m) outdoors, 660 ft. (200m) indoors
- E-964-Q165Q – 165 ft. (50m) outdoors, 330 ft. (100m) indoors



WARRANTY: This SECO-LARM product is warranted against defects in material and workmanship while used in normal service for a period of three (3) years from the date of sale to the original consumer customer. SECO-LARM's obligation is limited to the repair or replacement of any defective part if the unit is returned, transportation prepaid, to SECO-LARM.

This Warranty is void if damage is caused by or attributed to acts of God, physical or electrical misuse or abuse, neglect, repair, or alteration, improper or abnormal usage, or faulty installation, or if for any other reason SECO-LARM determines that such equipment is not operating properly as a result of causes other than defects in material and workmanship.

The sole obligation of SECO-LARM, and the purchaser's exclusive remedy, shall be limited to replacement or repair only, at SECO-LARM's option. In no event shall SECO-LARM be liable for any special, collateral, incidental, or consequential personal or property damages of any kind to the purchaser or anyone else.

NOTICE: The information and specifications printed in this manual are current at the time of publication. However, the SECO-LARM policy is one of continual development and improvement. For this reason, SECO-LARM reserves the right to change specifications without notice. SECO-LARM is also not responsible for misprints or typographical errors. Copyright © 2008 SECO-LARM U.S.A., Inc. All rights reserved. This material may not be reproduced or copied, in whole or in part, without the written permission of SECO-LARM.

SECO-LARM's ENFORCER Twin Photobeam detector series are protected by the following patents:
U.S. pat. no. D485774 ; Taiwan pat. no. 89463 ; China pat. no. ZL0331103.0
Other international patents are pending.

SECO-LARM[®] U.S.A., Inc.

16842 Millikan Avenue, Irvine, CA 92606

Tel: 800-662-0800 / 949-261-2999 Fax: 949-261-7326

 PITSW3
MIE964-D_US_P0804u.pmd

Website: www.seco-larm.com

E-mail: sales@seco-larm.com

SLI[®]
SECO-LARM

Note: Products with model number that ends with "Q" or have a green "Q" sticker represents RoHS compliant products.



TABLE OF CONTENTS

Introduction	2	Examples of Ways To Connect Sensors ...	7
Features	2	Selectable 4-channel Beam Frequency	8
Overview	3	Receiver Detail	8
Wiring Diagram	4	Beam Alignment Template	8
Choosing a Location	4	Beam Alignment	9
Running the Cable	4	Adjusting the Delay Time	10
Multiple Sensor Sample Applications	5	Testing the Unit	10
Typical Installations	5	Specifications	10
Wiring the Transmitter – Wall Mount	6	Dimensions	11
Wiring the Transmitter – Pole Mount	6	Troubleshooting	11
Wiring	6		

Introduction:

The ENFORCER E-964-Q Series Quad-Photobeam Sensors are ideal for long-distance protection. Four selectable beam frequencies allow for superior perimeter protection by eliminating crosstalk and interference between multiple units. False alarms created by animals and falling leaves are minimized by the sensor's detection method of all 4 beams simultaneously broken.

The E-964-Q Series of sensors is designed to work in even the most extreme conditions. A built-in heater automatically turns on and off depending on the outside temperature. An environmental control output senses a slow degradation in beam strength when weather conditions worsen preventing false alarms.

Installation and alignment is quick and easy with the ENFORCER E-964-Q Series. The built-in laser and visual alignment systems quickly and easily pinpoint the approximate mounting location for the transmitter and aid in aligning the transmitter and receiver units once mounted. A beam strength indicator clearly displays the strength of the beam at the receiver with 5 LEDs.

Features:

- Four selectable beam frequencies to eliminate interference between multiple units for enhanced perimeter protection.
- Audible beam alignment (buzzer).
- Beam strength indicator (5 LEDs).
- Environmental Output (Selectable N.O. or N.C.): Signal is sent if a degradation in environmental conditions is detected such as thickening fog to prevent false alarms.
- Built-in heater.
- IP-55 ingress protection.
- Lensed optics reinforce beam strength and provide excellent immunity to false alarms due to rain, snow, mist etc.
- Automatic input power filtering with special noise rejection circuitry.
- Voltage testing points for fine tuning the beam alignment.
- Input voltage: 12-24V AC/DC.
- Delay time adjustable for nearly all situations.

Fig. 15: Dimensions

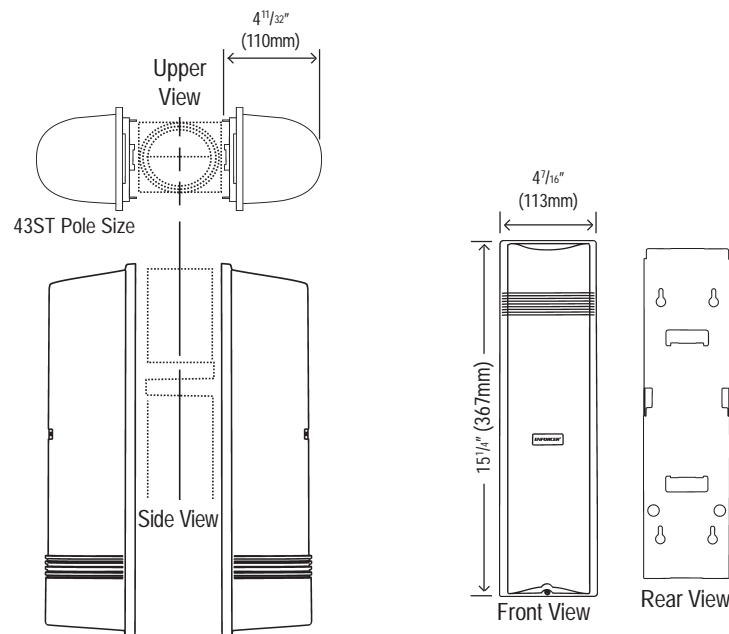

Troubleshooting:

Transmitter LED not lit	Make sure the input power to the transmitter is 12 to 24 VAC/VDC.
Receiver LED does not light when interrupted	Check the input power to the receiver is 12 to 24 VAC/VDC.
Beams are interrupted and LED lights, but the alarm does not trigger.	Check the continuity of the wiring from the receiver to the alarm.
Signal LED continuously lit	Clear any obstacles between the transmitter and receiver. Clean the lenses of both units.
Alarm trigger becomes erratic in bad weather	Check overall system installation. Realign the lenses.
Frequent false alarm triggers	Adjust the response time. Change location of transmitter and receiver.

Adjusting the Delay Time

- The delay time adjustment knob sets how long the beam can be interrupted before triggering the alarm (see fig. 13):
 - A short delay time (high sensitivity) is suitable for catching fast moving intruders, but more susceptible to false alarms.
 - A long delay time (low sensitivity) reduces false alarms, but fast moving intruders may not trigger the sensor.
- Adjust the knob to the site's situation. You may need to make adjustments later after the walk-through test.

Fig. 14:
Adjusting the Delay Time
(300ms)

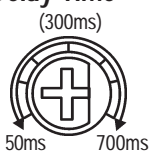

Testing the Unit

- Power up the transmitter and receiver.
- If the red alarm LED remains steady ON even when the beam is not interrupted, re-adjust the alignment.
- Walk between the transmitter and receiver to interrupt the beams. Walk at various speeds, and adjust the delay time adjustment knob as needed.

NOTE – The alarm will be triggered only if both the upper and lower beams are simultaneously interrupted.

IMPORTANT – Test the detector periodically to ensure the alignment and delay time settings are suitable for the site.

Table 4: Specifications

Model	E-964-Q165Q	E-964-Q330Q	E-964-Q495Q	E-964-Q660Q
Max. range (outdoor)	165' (50m)	330' (100m)	495' (150m)	660' (200m)
Max. range (indoor)	330' (100m)	660' (200m)	990' (300m)	1320' (400m)
Current (Tx & Rx)	110mA	115mA	120mA	125mA
Current (Tx & Rx & heaters)	260mA	270mA	280mA	290mA
Input voltage	12–24 VAC/VDC (non-polarity)			
Delay time	50msec–700msec (variable)			
Detection method	All 4 beams simultaneously broken			
Selectable beam frequencies	Four (4) channels			
Alarm output	Form "C" relay COM/N.O./N.C. 1A@125VAC/24VDC			
Tamper output (Tx & Rx)	NC switch, 1A @ 120VAC			
Environmental output	Selectable N.O. or N.C. 1A@125VAC/24VDC			
Beam-strength indicator	5 LEDs indicate signal strength from high to low			
Signal LED (Rx)	Red LED ON - beam is broken or Tx and Rx out of alignment			
Power LED (Tx & Rx)	Green LED - illuminated when power is on			
Laser wavelength	650nm			
Laser output power	≤5mW			
Alignment angle	Horizontal: ±90° Vertical: ±15°			
Operating temperature	-13~131°F (-25°~ 55°C)			
Weight	5.7 lbs. (2.6kg)			
Ingress protection	IP55			
Case	PC Resin			
Dimensions	15 ¹ / ₄ " x 4 ⁷ / ₁₆ " x 4 ¹¹ / ₃₂ " (387 x 113 x 110mm)			

* This is the minimum time interval between breaking of both beams which will trigger the output. Setting the interval longer will reduce false alarms from birds or falling leaves, etc., while setting it shorter will detect faster moving objects.

Fig. 1: Overview

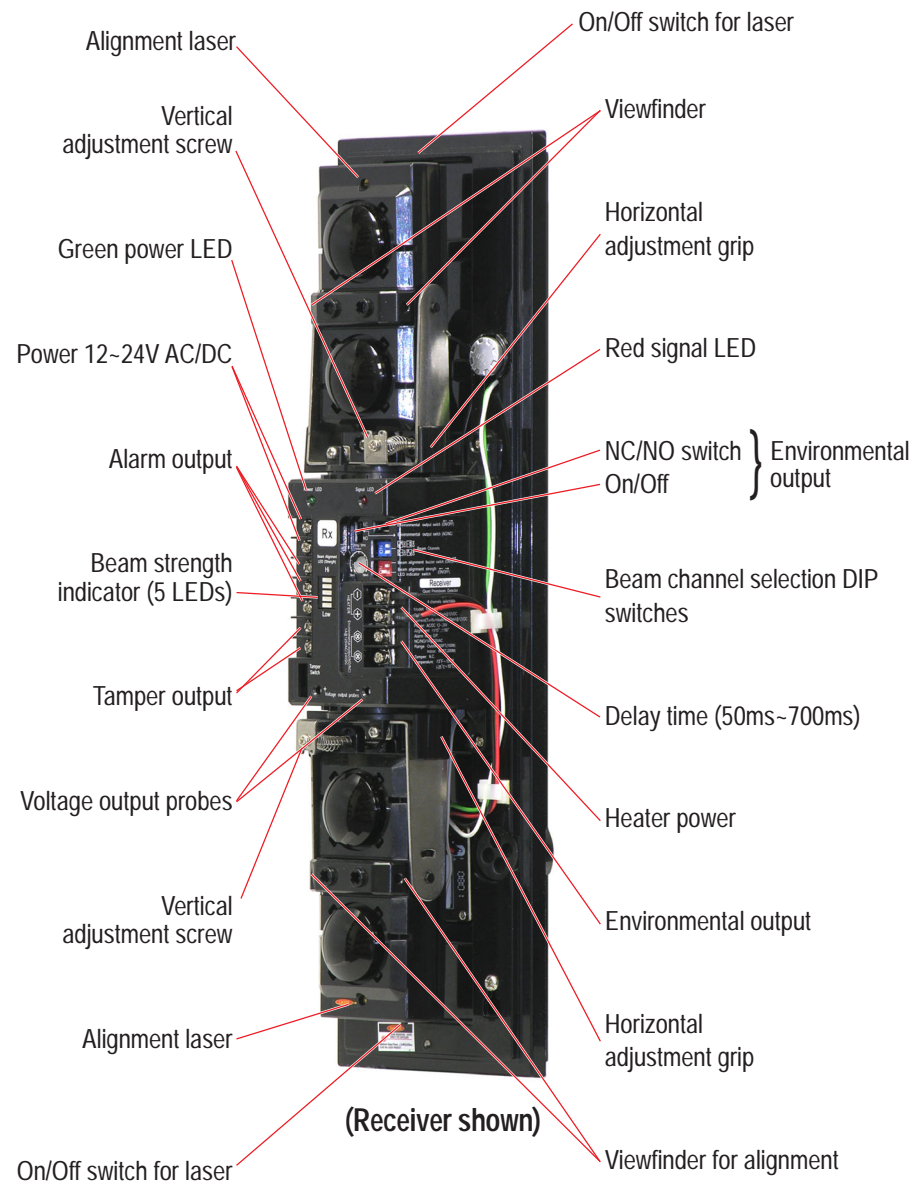

IMPORTANT – Do not connect to power until the sensor is completely installed and the installation has been double-checked.

Fig. 2: Wiring Diagram

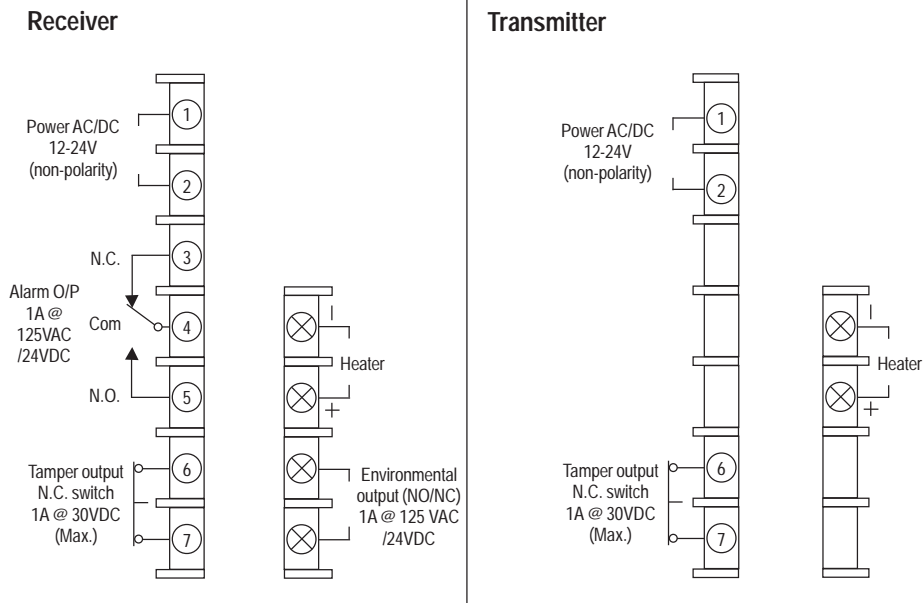

Choosing a Location

1. Find a suitable location for the receiver within wiring distance of a power supply and the alarm panel.
2. Establish a clear line-of-sight area between the receiver location and the transmitter location.
3. Make sure no trees or vegetation will cause false alarms during windy conditions.
4. Find locations away from standing water that could be splashed on to the receiver or the transmitter.
5. Do not mount the receiver where sunlight or bright lights shine directly into the unit.
6. Install at a distance of 32" to 39" (80 to 100 cm) above the ground for most situations. See fig. 3.

Running the Cable

Run a cable from the alarm control panel to the photobeam sensor. If burying the cable is required, make sure to use electrical conduit. Shielded cable is strongly suggested. See Table 1 for maximum cable length.

Table 1: Cable Length

Model	E-964-Q165Q		E-964-Q330Q		E-964-Q495Q		E-964-Q660Q	
	12V	24V	12V	24V	12V	24V	12V	24V
AWG22	320m 1,050ft.	2,800m 18,000ft.	280m 920ft.	2,400m 7,870ft.	200m 660ft.	1,600m 5,250ft.	110m 390ft.	900m 2,950ft.
AWG20	550m 1,800ft.	4,800m 15,750ft.	450m 1,480ft.	4,200m 13,780ft.	350m 1,150ft.	3,000m 9,840ft.	170m 560ft.	1,400m 4,590ft.
AWG18	800m 2,600ft.	7,200m 23,620ft.	700m 2,300ft.	6,200m 20,340ft.	500m 1,640ft.	4,200m 13,780ft.	250m 820ft.	2,200m 7,220ft.
AWG17	980m 3,190ft.	8,800m 28,870ft.	850m 2,790ft.	7,600m 24,930ft.	590m 1,940ft.	5,200m 17,060ft.	310m 1,020ft.	2,600m 8,530ft.

Note (1): Max. cable length when two or more sets are connected is the value shown in Table 1 divided by the no. of sets.

Beam Alignment Procedure

1. Remove the sensor cover and turn On the top and bottom lasers of both the transmitter and receiver. There are a total of four lasers.
2. Adjust the transmitter's sensor unit vertically and horizontally until the red dot is centered on the receiver and the receiver's signal LED turns Off.
3. Repeat step 2 for the receiver then turn Off the lasers.
4. Look through the viewfinder on the transmitter's lower sensor and adjust it vertically and horizontally until the receiver is clearly seen in the viewfinder.
5. Repeat step 4 for the receiver.
6. Turn On the beam alignment buzzer DIP switch (fig. 9). If the beams are not aligned the buzzer will sound.
7. Cover the top sensor on the receiver with the included template (as shown in fig. 10). Adjust the horizontal angle of the receiver's lower sensor vertically and horizontally until the buzzer stops sounding. Repeat while covering the lower sensor and adjusting the top sensor.
8. Turn the buzzer Off.
9. Turn On the beam strength Indicator DIP switch (fig. 9). If the beams are not aligned, the indicator will display little or no beam strength, see fig.12.
10. Cover the top sensor on the receiver. Adjust the horizontal angle of the receiver's lower sensor vertically and horizontally until the beam strength indicator displays a strong signal. Repeat while covering the lower sensor and adjusting the top sensor.
11. Turn the beam strength indicator Off.

Fig. 11: Horizontal and Vertical Sensor Adjustment

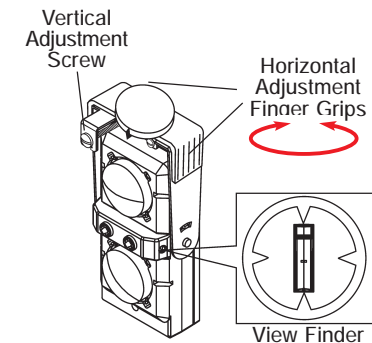

The transmitter and receiver sensor units can be adjusted $\pm 15^\circ$ vertically and $\pm 90^\circ$ horizontally once the unit is mounted and power is connected.



Fig. 12: Beam Strength Indicator



Fine Tuning

The most accurate way to align the transmitter and receiver is to measure the voltage using the voltage output jack.

1. Set the range of a multimeter to 0-10VDC.
2. Insert the red probe into the (+) terminal and the black probe into the (-) terminal.
3. Using Table 3, adjust the receiver's sensors vertically and horizontally until the best possible voltage output is achieved.

Fig. 13: Using a Multimeter for Fine Tuning

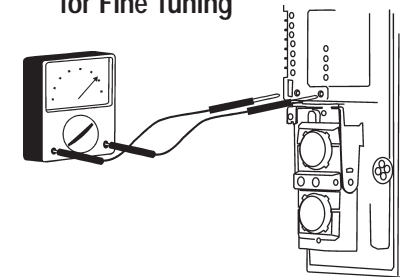

Table 3: Voltage Output

Voltage Output	<1.6	1.6-2.0V	2.0-2.4V	2.4-2.8V	2.8-3.2V	>3.2V
Alignment Quality	No Signal	Bad	Poor	OK	Good	Strongest

Selectable 4-channel beam frequency:

The sensor beam frequency can be set at different levels on-site to avoid interference from other photobeam sensors nearby. To select between four different beam frequencies, adjust the beam channel switch of the transmitter side and receiver side. See pg. 3, fig. 1 for switch location and table 2 for switch position.

Table 2: Channel Beam Frequency Selection Chart

Freq. channel	CH1	CH2	CH3	CH4
Switch position				

Important – The transmitter and receiver must be programmed to the same channel.

Fig. 9: Receiver Detail

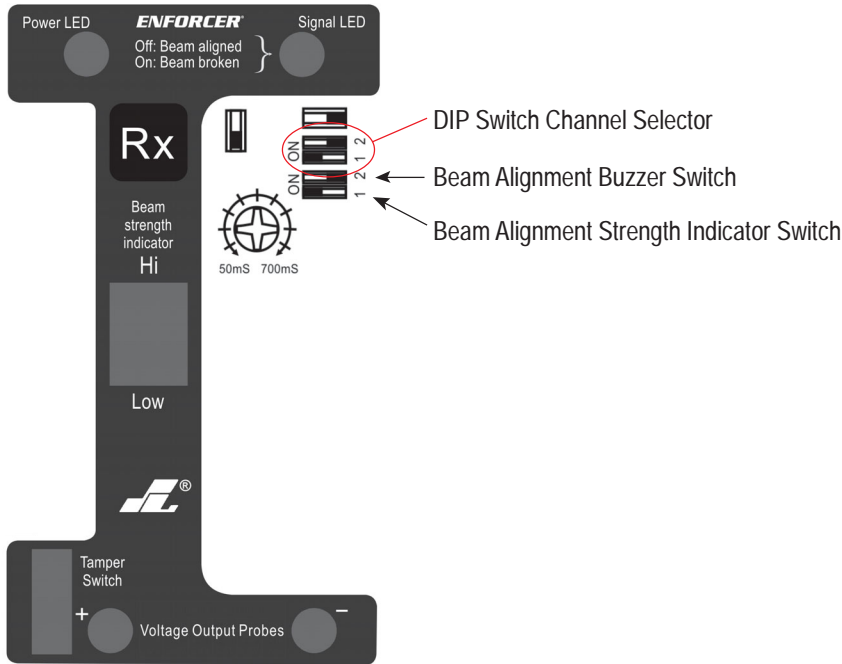
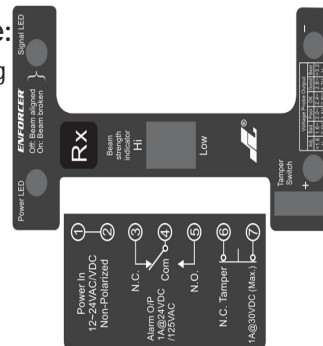

Fig. 10: Included Beam Alignment Template:

Use the included SECO-LARM template to aid in aligning the transmitter and receiver.



Multiple sensor sample applications

1. Long distance series application.

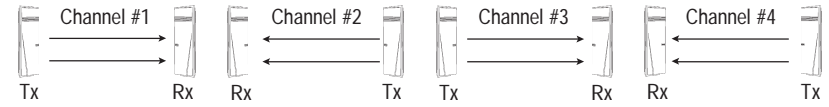

2. Two layer (double stacked) applications.

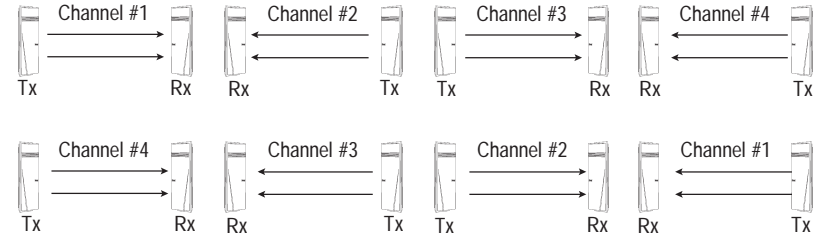

3. Perimeter security application.

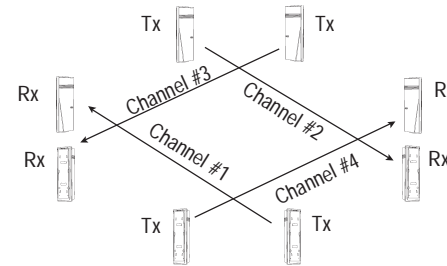

4. Single pair multiple layer application.

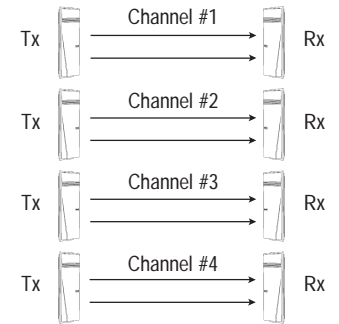
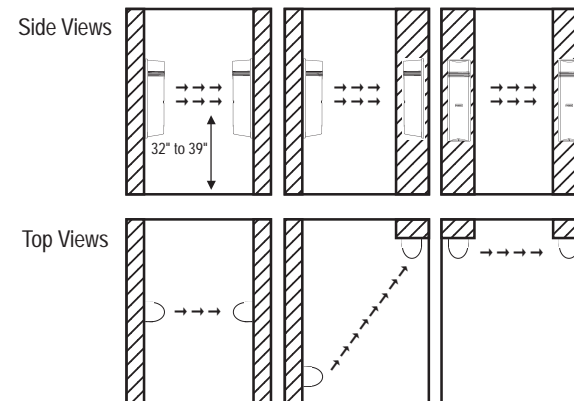

Fig. 3: Typical Installations



Wiring the Transmitter – Wall Mount

1. Remove the cover. Remove the screw under the lens unit in order to detach the mounting plate. See fig. 4.
2. If the sensor wiring comes from inside the wall – Break a hole in the mounting plate's rubber grommet, and pull the cable through the hole near the bottom of the sensor unit so it comes out the front. Using two of the included mounting screws, attach the mounting plate to the wall. Then reattach the sensor unit to the mounting plate, connect the wires, and snap on the cover. See fig. 5.
3. If the sensor wiring is run along the surface of the wall – There are four plastic knockouts on the back of the sensor unit, two on top and two on bottom. Break out the appropriate knockout, and pull the wiring through the knockout. Then run the wiring through the hole near the bottom of the sensor unit so it comes out the front. Using two of the included mounting screws, attach the mounting plate to the wall. Then reattach the sensor unit to the mounting plate, connect the wires, and snap on the cover. See fig. 6.

Wiring the Transmitter – Pole Mount

(NOTE – Pole mounting bracket included.)

1. Remove the cover. Remove the screw under the lens unit in order to detach the mounting plate. See fig. 4.
2. Break a hole in the mounting plate's rubber grommet, and pull the cable through the hole near the bottom of the sensor unit so it comes out the front. Use the included mounting bracket to mount to the pole. Then reattach the sensor unit to the mounting plate, connect the wires, and snap on the cover. See fig. 7.

Wiring (fig. 8)

1. Screw the wires tightly to avoid slipping off the terminals, but not so tight that they break.
2. Screws on terminals which are not used should be tightened.
3. Grounding may be necessary, depending on the location.

Fig. 4:
Remove the Transmitter cover

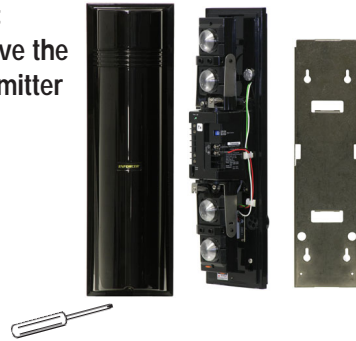

Fig. 5:
Wall Mount, Wire from Inside Wall

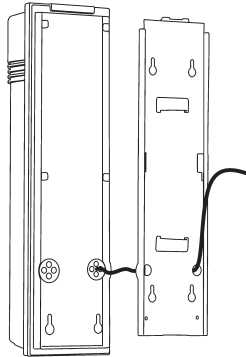

Fig. 6:
Wall Mount, Wire Runs Along Wall

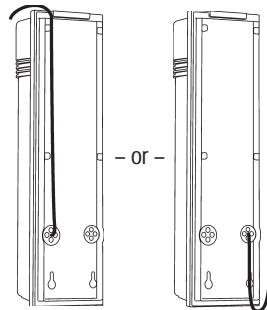

Fig. 7:
Pole Mount

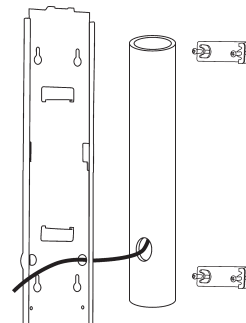
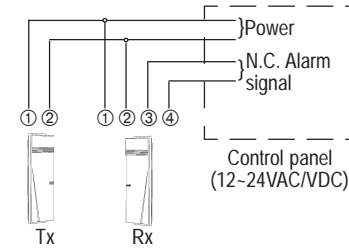
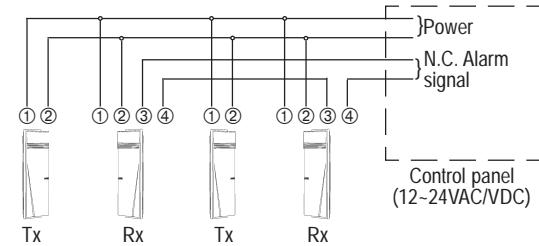

Fig. 8: Examples of Possible Ways To Connect One or More Sensors

Example connection 1 - Standard



Example connection 2 - In-line Single Channel



Example connection 3 - Dual Sensors, Separate Channels

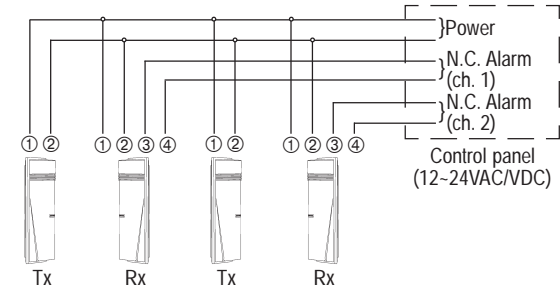

Example connection 4 - Two stacked

