

ELECTROMAGNETIC GATE LOCK INSTALLATION INSTRUCTIONS

※Model:

G-LOCK/600

※Feature:

- Threaded conduit fitting
- Stainless Steel Case
- Built-in lock status sensor
- Suitable for outdoor
- Waterproof

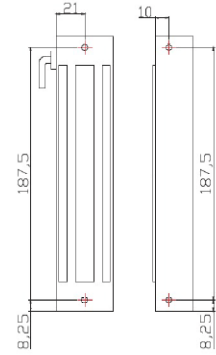
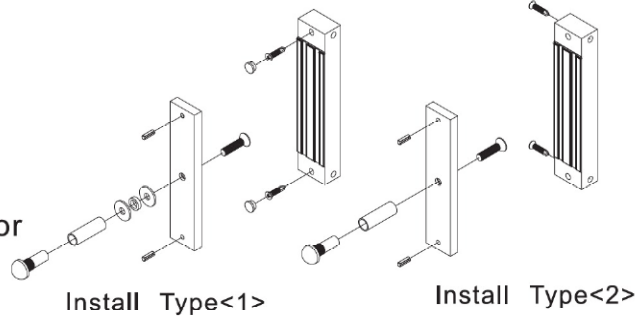

※Specifications:

	G-LOCK/600	Note
Power supply	DC-12V / DC-24V	Switchable
Operation current	420mA/12VDC 210mA/24VDC	
Lock status sensor	N.C. and N.O. output	Reed switch
Holding force	600lbs(250kg)	
Operation temperature	-10°C ~ 70°C	
Warranty	1 year	
Weight	2kg	
Body Dimensions	204 L X 42 W X 28 D (mm)	
Armature Dimensions	185 L X 38 W X 12 D (mm)	
Casing	Stainless Steel	

Please read before installing
Specific mounting brackets may be necessary to fit different types of gate.

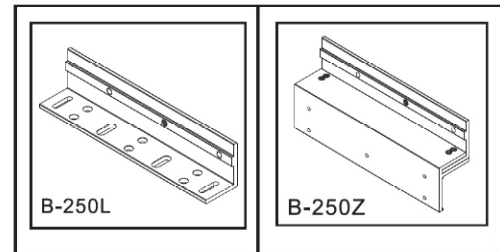

※Accessories diagram:

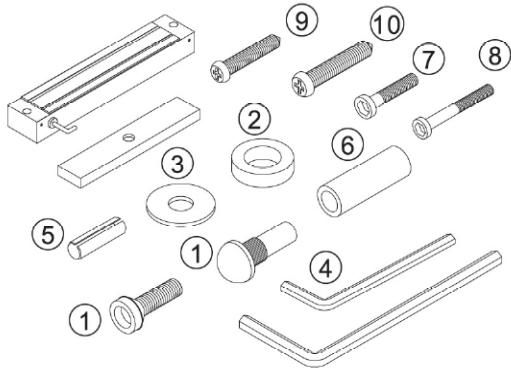

Accessories:

Type	Quantity	Model Type	ML-250	
1	Sexnut Bolt	1		
2	Rubber Washer	2		
3	Washer	3		
4	Allenkey	2		
5	Guide pins	2		
6	Door spacer	1		
7	Mounting screw	2	M4x30mm	
8	Mounting screw	2	M4x40mm	
9	Mounting screw	2	M4x35mm	
10	Mounting screw	2	M4x50mm	

Installation

- Determine the type of gate (refer to Fig 1 & Fig 2 & Fig 3). Please make sure type of gate (please refer to fig. 2 & fig 3) to ensure the type of brackets required to install.
- Prepare the gate post for mounting the gate lock and armature. Determine the desired location for mounting the gate lock and armature on the gate post. Make sure there is space for wiring.
- Mount the lock body.
- Mount the armature. If you are mounting the armature directly to the gate, you can refer to fig 5 for drilling the armature mounting screw hole.
- Verify proper alignment. Close the gate and verify the lock face and armature are making full contact of the entire armature length. Adjustments may be needed.
- Connect the wires. Refer to Connection Diagram and Monitor Output for wiring.
- Test the unit.
- Insert the tamper caps into the mounting screw access holes of the lock body. This should be the last step of the installation, as once the tamper caps are in place, it is difficult to remove.

Installation diagram

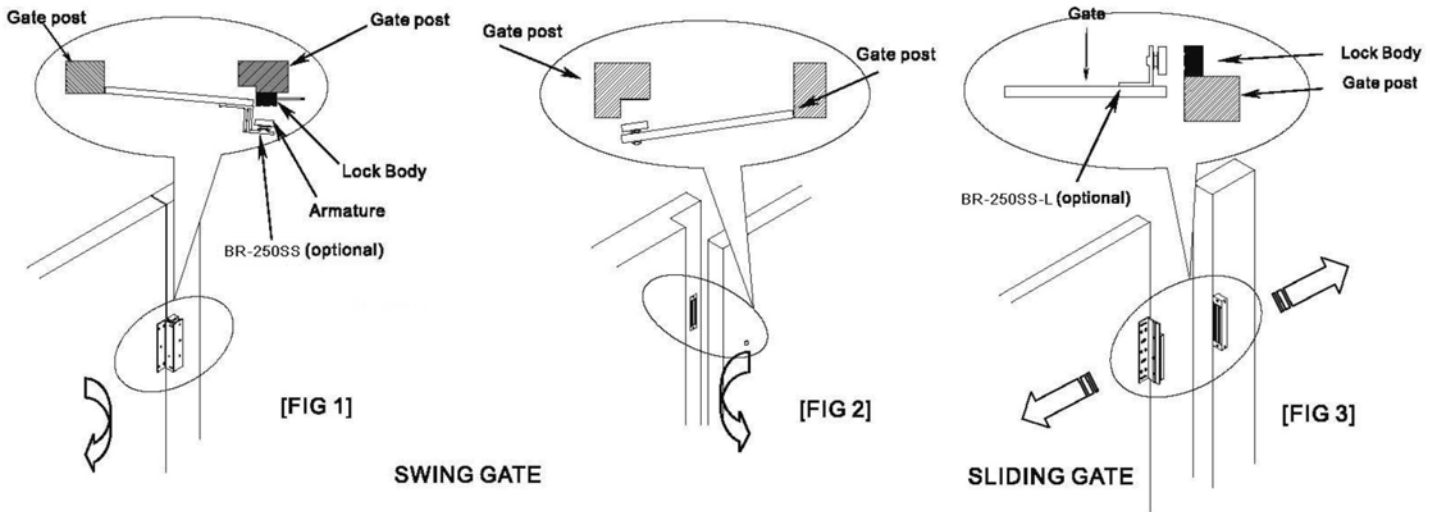

Armature installations

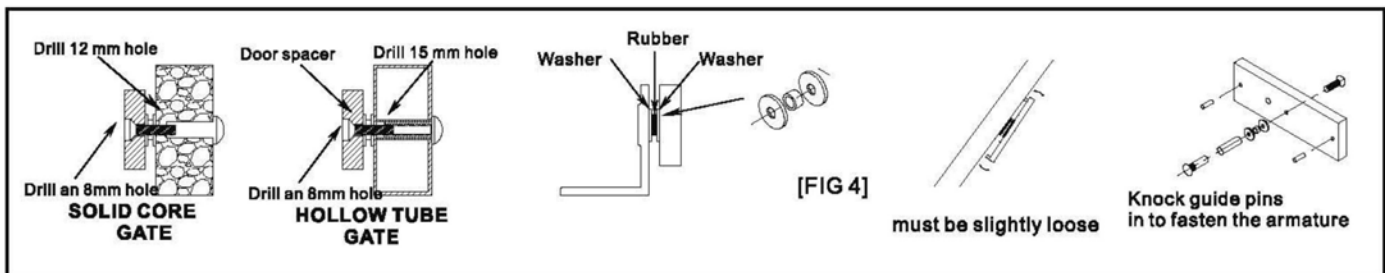

Connection Diagram and Monitor Output

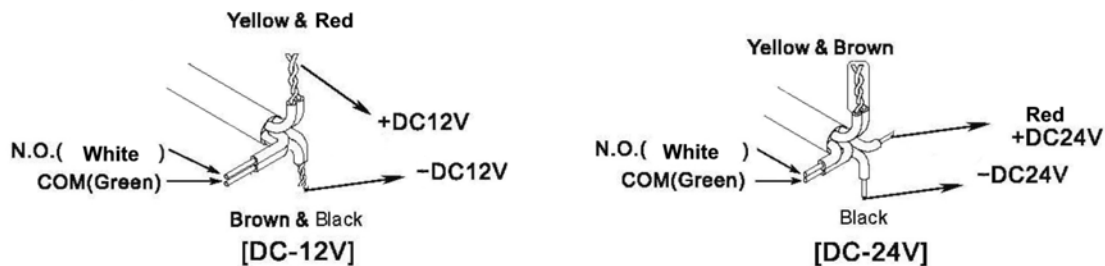

*Monitor output, contact rating (60VDC/0.25A)

*When magnetic lock and armature are engaged, the monitor output will change to N.O. status.

Problem :	Possible cause :	Solutions :
Door does not lock.	No power.	<ul style="list-style-type: none"> Check the input voltage at the EM-lock. If the voltage is zero or a low reading, double check all wire connections.
	Incorrect wiring.	<ul style="list-style-type: none"> Refer to Connection Diagram and monitor output.
Low holding force.	Lock body and armature plate did not contact properly.	<ul style="list-style-type: none"> Make sure the lock body and armature plate are properly aligned. Make sure the contact surfaces of the lock body and armature plate are clean and free from rust.
	Incorrect voltage setting	<ul style="list-style-type: none"> Check the power adapter with a meter, and make sure the wiring is connected correctly (DC12V/24V).
	AC voltage supply.	<p>EM-lock requires DC input voltage. When an AC transformer is used, a bridge rectifier must be installed to convert the AC output of the transformer to DC output.</p>